



Kent County Road Commission

COMMERCIAL DRIVEWAYS AND PRIVATE STREET ENTRANCES ON COUNTY ROADS

1. Permit application(s) shall be in accordance with the attached GENERAL REQUIREMENTS and the following instructions.
2. The Kent County Road Commission (K.C.R.C) will advise the Applicant in the completion of the application and drive plan, but will not prepare the plan. Two copies of the drive plan must be submitted to the Kent County Road Commission Permit Department (616) 242-6920, FAX (616) 336-4397.
3. Any utility work in the right of way must be applied for on a separate application along with two copies of the utility plan submitted to Kent County Road Commission Permit Department (616) 242-6920, FAX (616) 336-4397.
4. OWNER, not Contractor must sign the application for the driveway. The original signed application must be returned; no faxes or photocopies will be accepted. Review/Permit fees (non-refundable) of \$250.00 (uncurbed) or \$300.00 (curbed) for the first driveway and \$100.00 for each additional driveway must accompany the application. Separate Review/Permit fees, and bonds for utilities will be determined by the Permit Department. Check(s) should be made out to the "KENT COUNTY ROAD COMMISSION".
5. OWNER, not Contractor must provide a surety with either a Performance Bond, Check, or Bank Letter of Credit in the amount of \$20,000 for the first driveway and \$10,000 for each additional driveway. Where road improvements are required on the existing public road in conjunction with the drive(s), the total surety amount will also include the estimated road improvement cost (plus 20% contingency). The K.C.R.C. bond form must be signed and returned with original signatures, no faxes or photocopies will be accepted. Checks will be deposited/cashed and the money will be refunded by check after final inspection approval of the completed approach by the K.C.R.C. Inspector.
6. When the above criteria has been met, the Kent County Road Commission will review the submitted plan for issuance of a permit. However, issuance of a permit does not relieve the Applicant (Owner) of responsibility for local ordinances or state laws. All work allowed by the permit must be completed within one year from date of issue. Failure to do so could result in an additional application fee, as well as the surety (Bond, Bank Letter of Credit, Check) being utilized by the Kent County Road Commission.
7. The Kent County Road Commission must inspect forms prior to placement of concrete, but will not do any staking for forms.

Questions regarding design of driveways/approaches can be directed to Dave Beck at (616) – 242-6901 Ext. 2992. **Personal meetings require an appointment.**

Effective: February 13, 2018

GENERAL REQUIREMENTS
for Commercial Driveways and Private Street Entrances
on County Roads
Page 1 of 3

A. APPLICATION REQUIREMENTS

1. All applications shall be on the K.C.R.C application form, completed and signed by the Applicant (Owner). An original form must be returned; no faxes or photocopies will be accepted. No plan review will be performed without a completed application submitted.
2. All entries on the application must be printed or typewritten, except the signature. The name of the Contractor who will actually be performing the work is to be listed if known at the time of application.
3. The name of the Applicant (Owner) must be printed or typed below their signature. Address must be complete, including city, state, zip code, and owners phone number.
4. The Applicant (Owner) name/signature on the application must be the same as the Principal's name/signature on the Performance Bond Form, or Bank Letter of Credit.

B. PLAN REQUIREMENTS

1. All drawings and sketches accompanying an application are referred to as a plan, and must meet the following requirements:
 - a. Two copies (or sets) of the plan must be provided with the application unless otherwise approved. A Civil Engineer must prepare the plan, or someone with extensive experience in civil/traffic engineering road design. Plan design setup must meet K.C.R.C. requirements (see engineer for details).
 - b. A driveway approach including concrete curbed radii shall be located entirely within the area between the Applicants/Owners property/easement lines; extended to the centerline of the highway. A concrete curbed radius may extend outside of that area only if the adjacent property owner certifies in writing that he/she will permit such extension across their frontage.
 - c. It is in the interest of the Applicant (Owner) to review with the Permit Department the specific plan items required, prior to development of the plan, which will accompany the permit application. Unless waived by the reviewing agent, a plan must include the following:
 - (1) A plan view of the entire area of right of way prepared at a scale of at least 1" = 20 feet or 1" = 10 feet on sheet paper at least 24" x 36" in size.
 - (2) All right of way lines and property/easement lines pertinent to the proposed construction.
 - (3) The highway pavement width (from the centerline of pavement to the edge of the highway or white paint edge line), and shoulder widths (paved and/or gravel).
 - (4) The distance between the centerline of highway pavement and the right of way line.

GENERAL REQUIREMENTS
for Commercial Driveways and Private Street Entrances
on County Roads
Page 2 of 3

- (5) Buildings, both proposed and existing, and notation as to present use of the buildings. Details of internal traffic circulation, parking, and traffic signs may be required.
- (6) Proposed details should include widths of driveways, radii of driveway returns and other points of curvature, driveway grades, angle of the driveway relative to the road centerline, dimensions of traffic islands adjacent to the highway, driveway surface material and traffic island surface material.
- (7) From proposed drive centerline, include distance to nearest intersecting public roadway, nearest driveway(s) within 300' on adjacent properties and driveway(s) within 300' opposite the site. In addition, location of trees, curbs, sidewalks, signs, power poles, hydrants, catch basins, manholes, utilities, etc. must be shown where applicable.
- (8) Drainage information shall include existing site elevations, gutter elevations, drive culvert size, direction of water flow, proposed drainage outlets and all invert elevations, outlet pipe size and material. The Kent County Road Commission will not accept storm water run-off that does not presently drain towards the right of way. Any run-off as a result of improvements to the site will be detained through the use of on-site detention with a controlled outlet. Run-off calculations and computations for the detention pond volume shall be submitted as part of the application. Before and after contours may be required.
- (9) A north directional arrow (oriented with north pointing to the top, or to the right of the plan sheet), scale size, and an explanatory legend of any engineering symbols used.

C. FEE

1. A Review/Permit Fee is required in accordance with the current fee schedule. No plan review will be performed without a Review/Permit Fee submitted.
2. Payment by check or money order is preferred, made payable to the Kent County Road Commission.

D. BOND, CHECK, BANK LETTER OF CREDIT

1. For a Performance Bond, only the K.C.R.C. Bond Form will be accepted. The form must be made out with the Applicant (Owner) as the Principal. The original form must be returned with the signatures of Principal and Surety in original ink. A Power of Attorney Form from the Surety must accompany the bond.
2. A Check made payable to the Kent County Road Commission may be submitted in lieu of a Performance Bond. Checks will be deposited/cashed and the money will be refunded by check after final inspection approval of the completed approach by the K.C.R.C. Inspector.
3. For a Bank Letter of Credit, only the K.C.R.C. Letter of Credit Form will be accepted. Letters of Credit must be in effect for a minimum of one year, and must have an automatic renewal statement unless cancelled by an authorized agent of the Kent County Road Commission.

GENERAL REQUIREMENTS
for Commercial Driveways and Private Street Entrances
on County Roads
Page 3 of 3

E. CAUTION

1. Submit applications well before you plan to start on site construction; four to six weeks may be required for processing.
2. The Permittee will be required to:
 - a. Give notice in such form as requested to the Road Commission's Utilities-Permit designated representative at least two (2) days prior to commencement of any operations covered by the permit, or as specified.
 - b. Provide all necessary staking and supervision of operations covered by the permit. Forms for concrete curb may be checked by the Road Commission's representative upon proper notice but this shall not relieve the Permittee of responsibility to insure conformance with the permit and applicable Road Commission Standards. The Applicant (Owner) is responsible for the performance and actions of the Contractor. Failure of the Contractor to comply with the permit requirements may result in the suspension or cancellation of the permit.
 - c. Perform no work except emergency work, unless authorized by the Road Commission on Saturdays, Sundays or from 3:00 PM on the day preceding a holiday until the formal starting time on the day after the following holidays: New Year's Day, Memorial Day, Independence Day, Labor Day, Thanksgiving Day, and Christmas Eve and Christmas Day.
 - d. Provide and maintain all necessary precautions to prevent injury or damage to persons and property from operations covered by the permit.
 - e. Furnish, install and maintain all necessary traffic controls and protection during construction operations in the highway right of way in accordance with the Michigan Manual of Uniform Control Devices and any supplemental specifications set forth herein.
 - f. Advise the Road Commission's Utilities-Permits Engineer or his designated representative within seven (7) days of completion of work authorized by the permit so that final inspection may be made and where appropriate, the surety bond released.
3. Failure to comply with these requirements may result in the delay of permit approval and/or rejection of the permit application.

ADDITIONAL REQUIREMENT FOR WORK WITHIN
COUNTY HIGHWAY RIGHT OF WAY

NOTICE

PERMIT APPLICANTS AND THEIR CONTRACTORS ARE SUBJECT TO:

PARK 91, SOIL EROSION AND SEDIMENTATION CONTROL (SESC), of the Natural Resources and Environmental Protection Act, 1994 PA 451, as Amended. A permit may be required for SESC.

Contact the KCRC Permit Department at 616-242-6920.

NOTICE

ADDITIONAL HIGHWAY PERMIT APPLICATION FORMS AND PERFORMANCE BOND FORMS CAN BE OBTAINED FROM THE KENT COUNTY ROAD COMMISSIONS WEB SITE AT:

WWW.KENTCOUNTYROADS.NET

ON THE UPPER SIDE OF YOUR SCREEN CLICK ON “DOING BUSINESS”. THEN CLICK ON “PERMITS”. SCROLL DOWN TO COMMERCIAL DRIVEWAY/PRIVATE STREET APPROACH. CLICK EITHER ON DOWNLOAD APPLICATION OR DOWNLOAD PERFORMANCE BOND TO OBTAIN YOUR NEEDED FORM. MAKE SURE THE FORMS ARE SIGNED BEFORE YOU SUBMIT THEM.

COMMERCIAL DRIVE ALL IN ONE INFORMATION PACKETS ARE ALSO FOUND UNDER THIS COMMERCIAL DRIVEWAY/PRIVATE STREET APPROACH CATEGORY.

KENT COUNTY ROAD COMMISSION
APPLICATION FOR HIGHWAY PERMIT

Date _____ 20__

Road name _____ Width of R.O.W. _____ ft.

Location of the Work _____

Telephone # _____ Fax # _____ E-mail _____

Contractor _____ Address _____

Applicant /Owner _____ Address _____

This application, if approved, shall authorize only the work described herein. No other work shall be performed within the highway right-of-way by the applicant or any other party (including, without limitation, the installation of additional wires or lines along or within any facilities or structures described with this application) without a separate written application approved by the Kent County Road Commission. The Kent County Road Commission shall not be responsible for any damage to wires, poles, conduits or any other facilities or structures constructed or installed within the highway right-of-way without written application approved by the Road Commission.

Permission is requested to do the following work within the limits of the highway right-of-way and it is hereby agreed to do this work in accordance with the "Specifications and Conditions" of the Kent County Road Commission.

**DETAILED PLANS OF THE WORK MUST ACCOMPANY THIS APPLICATION
IN THE AREA BELOW DESCRIBE THE WORK REQUESTED TO BE DONE IN THE HIGHWAY RIGHT OF WAY**

Work to commence _____, 20____, and to be completed _____, 20____.

The undersigned further agrees that if this application is approved, he will meet all legal requirements; and that he will be responsible to the Kent County Road Commission for any damages to the highway or to the highway structures or the structures of any private company within the right-of-way of the highway, and that he shall, well and truly, pay all damages, fines and penalties which he shall become liable to pay and shall save the Kent County Road Commission harmless from all suits, claims, damages and proceedings of any kind due to his operations within the highway right-of-way.

Signature of Applicant/Owner _____ for _____

Approved by _____ of Engineering Dept. Date _____

Approved by _____ of Maintenance Dept. Date _____

Approved by _____ of Traffic Dept. Date _____

TERMS AND CONDITIONS

1. **Specifications.** All work performed under this permit must be done in accordance with the application, plans, specifications, maps and statements filed with the County Road Commission ("Road Commission") and must comply with the Road Commission's current procedures and regulations on file at its offices and the current MDOT Standard Specifications for Construction, if applicable.
2. **Fees and Costs.** The Permit Holder shall be responsible for all costs incurred by the Road Commission in connection with this permit and shall deposit estimated fees and costs as determined by the Road Commission, at the time the permit is issued.
3. **Bond.** The Permit Holder shall provide a cash deposit, irrevocable letter of credit or bond in a form and amount acceptable to the Road Commission at the time permit is issued.
4. **Insurance.** The Permit Holder shall furnish proof of general liability insurance in amounts not less than \$1,000,000 each occurrence and general aggregate, proof of automobile liability in amounts not less than \$1,000,000 combined single limit for each accident, bodily injury per accident, and property damage per accident, and in an amount not less than \$500,000 for bodily injury per person. Such proof of insurance shall include a valid certificate of insurance demonstrating that the Road Commission is an additional insured party on the policy. Such insurance shall cover a period not less than the term of this permit and shall provide that it cannot be cancelled without 30 days advance written notice to the Road Commission, by certified mail, first-class, return receipt requested. This permit is invalid if insurance expires during the authorized period of work described herein.
5. **Indemnification.** In addition to any liability or obligation of the Permit Holder that may otherwise exist, Permit Holder shall, to the fullest extent permitted by law, indemnify and hold harmless the Road Commission and its commissioners, officers, agents, and employees from and against any and all claims, actions, proceedings, liabilities, losses, and damages thereof, and any and all costs and expenses, including legal fees, associated therewith which the Road Commission may sustain by reason of claims for or allegations of the negligence or violation of the terms and conditions of this permit by the Permit Holder, its officers, agents, or employees, arising out of the work which is the subject of this permit, or arising out of work not authorized by this permit, or arising out of the continued existence of the operation or facility, which is the subject of this permit.
6. **Miss Dig.** The Permit Holder must comply with the requirements of Act 53 of Public Acts of 1974, as amended. CALL MISS DIG AT (800) 482-7171 or www.missdig.org AT LEAST THREE (3) FULL WORKING DAYS, BUT NOT MORE THAN FOURTEEN (14) CALENDAR DAYS, BEFORE YOU START WORK. The Permit Holder assumes all responsibility for damage to or interruption of underground utilities.
7. **Notification of Start and Completion of Work.** The Permit Holder must notify the Road Commission at least 48 hours before starting work, when work is completed, and additionally as directed by the Road Commission.
8. **Time Restrictions.** All work shall be performed Mondays through Fridays between and unless written approval is obtained from the Road Commission, and work shall be performed only during the period set forth in this permit. Perform no work except emergency work, unless authorized by the Road Commission on Saturdays, Sundays, or from on the day proceeding until the normal starting time the day after the following holidays: New Year's Day, Memorial Day, Independence Day, Labor Day, Thanksgiving Day and Christmas Day.
9. **Safety.** Furnish, install and maintain all necessary traffic controls and protection during Permit Holder's operations in accordance with the Manual of Uniform Traffic Control Devices, Part 6 and any supplemental specifications set forth herein.
10. **Restoration and Repair of Road.** The construction, operation and maintenance of the activity covered by this permit shall be performed by the Permit Holder without cost to the Road Commission unless specified herein. The Permit Holder shall also be responsible for the cost of restoration and repair of the right-of-way determined by the Road Commission to be damaged as a result of the activity which is the subject of this permit. Restoration shall meet or exceed conditions when work is commenced and be in accordance with specifications. The Permit Holder shall be responsible for costs incurred by the Road Commission for emergency repairs performed by or on behalf of the Road Commission for the safety of the motoring public. Said repairs shall be performed with or without notice to the Permit Holder if immediate action is required. This determination shall be in the sole and reasonable opinion of the Road Commission.
11. **Limitation of Permit.** Issuance of this permit does not relieve Permit Holder from meeting any and all requirements of law, or of other public bodies or agencies. The Permit Holder shall be responsible for securing and shall secure any other permits or permission necessary or required by law from cities, villages, townships, corporations, property owners, or individuals for the activities hereby permitted. Any work not described by the application, including the time and place thereof, is strictly prohibited in the absence of the application for and issuance of an additional permit or amendment to this permit.
12. **Revocation of Permit.** This permit may be suspended or revoked at will, and the Permit Holder shall surrender this permit and alter, relocate or remove its facilities at its expense at the request of the Road Commission. It is understood that the rights granted herein are revocable at the will of the Road Commission and that the Permit Holder acquires no rights in the right-of-way and expressly waives any right to claim damages or compensation in case this permit is revoked.
13. **Assignability.** This permit is not assignable and not transferable unless specifically agreed to by the Road Commission.
14. **Authority.** The statutory authority of the Road Commission to require compliance with permit requirements is predicated upon its jurisdictional authority and is set forth in various statutes including, without limitation and in no particular order, MCL §247.321 et seq; MCL §224.19b; MCL §560.101 et seq; and MCL §247.171 et seq.

KENT COUNTY ROAD COMMISSION BOND FORM

FOR COMMERCIAL DRIVEWAYS AND PRIVATE STREET APPROACHES

For a performance bond, only the Kent County Road Commission bond form will be accepted.

The form must be made out with the property owner as the principal.

An original blue ink signature copy must be submitted; signatures of principal and surety must be original.

Three photocopies of the blue ink signature copy must also be attached.

In addition, a power of attorney form from the surety must be attached to the submitted bond form.

BOND NO. _____

K.C.R.C. PLAN NO. _____

KENT COUNTY ROAD COMMISSION

BOND

TO ACCOMPANY APPLICATION FOR PERMIT

KNOW ALL MEN BY THESE PRESENTS,

That _____ as Principal, and

as surety are held and firmly bound unto the County of Kent, and the Board of Kent County Road Commissioners or their assigns, in the penal sum of _____ Dollars, lawful money of the United States of America, for the payment of which, well and truly to be made to the said County of Kent and the Board of Kent County Road Commissioners or their assigns, we bind ourselves, our heirs, executors and administrators, jointly and severally, firmly by these presents.

Sealed with our seals and dated this _____ day of _____ A.D. 20_____

WHEREAS, the above bounden _____ has made application to said Kent County Road Commission for a permit as stated in the application therefore.

NOW THEREFORE, The condition of this obligation is such that if the above bounden Principal shall do and perform all work done and performed under said permit in a careful, secure, skillful and workmanlike manner, and shall so guard the work authorized by the said permit, and the materials for use during the progress thereof, that no injury, loss or damage shall occur to persons or property, and shall promptly at the conclusion of such work replace and restore the street or highway and right of way to as good a state and condition as the same was previous to and at the time of opening of the same, and shall so replace and restore such street or highway and right of way as to cause it to be in a state of reasonable repair so as to be reasonably safe and convenient for public travel, and the satisfaction of the Board of Kent County Road Commissioners, and shall save the County of Kent and/or said Board of Kent County Road Commissioners harmless from all claims, suits, actions, damages, or judgments against it which shall arise out of any failure on the part of the above bounden Principal to comply with the terms of this bond, and if the said above bounden Principal shall also observe the statutes of the State of Michigan, and the ordinances of the County of Kent, shall comply with all articles set forth in the permits and shall pay all bills rendered by said Board of Kent County Road Commissioners to complete or repair in accordance with permit requirements, or replacement of pavement, roadway and right of way where disturbed or displaced by this work, then this obligation shall be null and void, otherwise to be and remain in full force and effect.

Principal _____ (Signature)

Principal's Address _____

Surety _____ (Signature)

Surety's Address _____

DO NOT WRITE BELOW THIS LINE - FOR USE OF PERMIT DEPT. ONLY

INSTRUCTIONS TO PERMIT DEPT. - Original signature form and all photocopies to be retained on file. At the time permit is issued, lower left block to be filled out on original and all copies. For bond release, when work is satisfactorily completed or permit is cancelled, lower right hand block to be filled out on original and all copies. Once released, a copy shall be sent to the Principal for them to forward to their Bonding Agent.

NOTICE TO SURETY OF PERMIT ISSUANCE

This is to inform you that a permit, covered by the above bond, has been issued as follows:

APPLICATION NO.

PERMIT NO.

DATE

OWNER

CONTRACTOR

Please include this information on all correspondence concerning the bond

NOTICE OF TERMINATION OF LIABILITY

This is to inform you that:

The permit operations covered by the above bond have been satisfactorily completed.

The permit covered by the above bond has been cancelled.

Liability under the bond is therefore terminated, effective _____

By: _____

Title _____

KENT COUNTY ROAD COMMISSION

STANDARD COMMERCIAL DRIVEWAY

DETAIL "A"

PRIVATE STREET ENTRANCE (EXAMPLE) RURAL
COUNTY ROAD WITH A.D.T. UNDER 1,000

FOR CULVERTS WHERE APPLICABLE, CORRUGATED METAL
PIPE (MIN. 12" I.D.) OR SMOOTH LINED CORRUGATED
PLASTIC PIPE (TYPE S - MIN. 12" I.D.) MAY BE USED.
MUST MEET KCRC REQUIREMENTS.

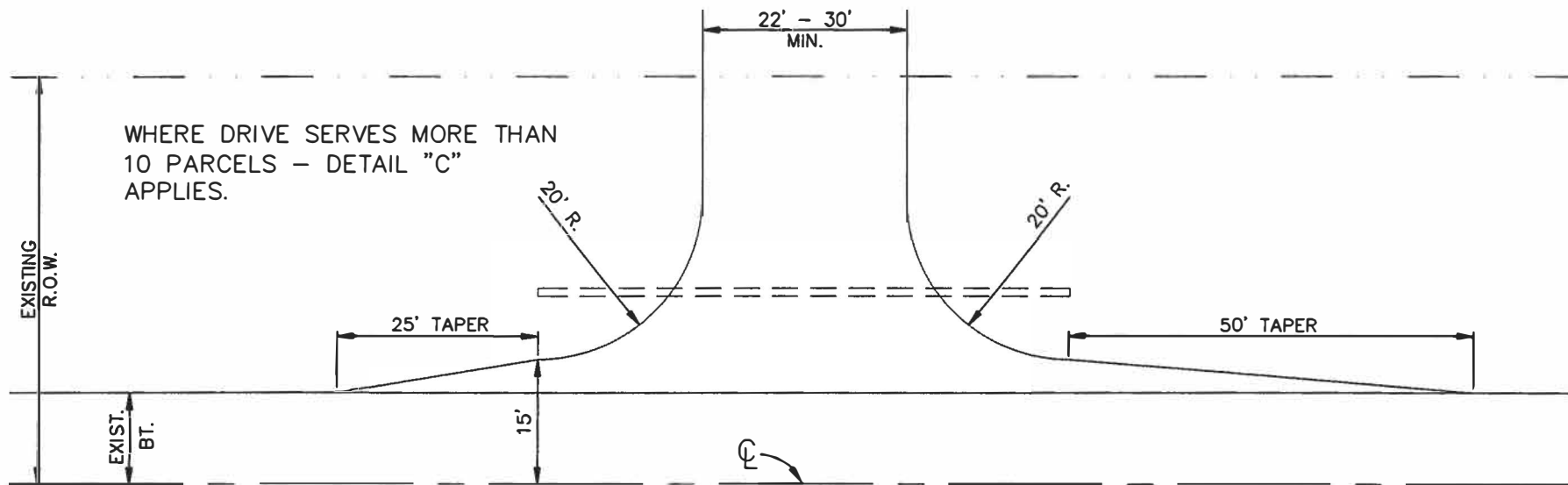

KENT COUNTY ROAD COMMISSION

STANDARD COMMERCIAL DRIVEWAY

DETAIL "B"

PRIVATE STREET ENTRANCE (EXAMPLE) RURAL COUNTY ROAD WITH A.D.T. BETWEEN 1,000 - 2,000

WHERE DRIVE SERVES MORE THAN 10 PARCELS - DETAIL "C" APPLIES.

FOR CULVERTS WHERE APPLICABLE, CORRUGATED METAL PIPE (MIN. 12" I.D.) OR SMOOTH LINED CORRUGATED PLASTIC PIPE (TYPE S - MIN. 12" I.D.) MAY BE USED. MUST MEET KCRC REQUIREMENTS.

CURB AND GUTTER IS OPTIONAL

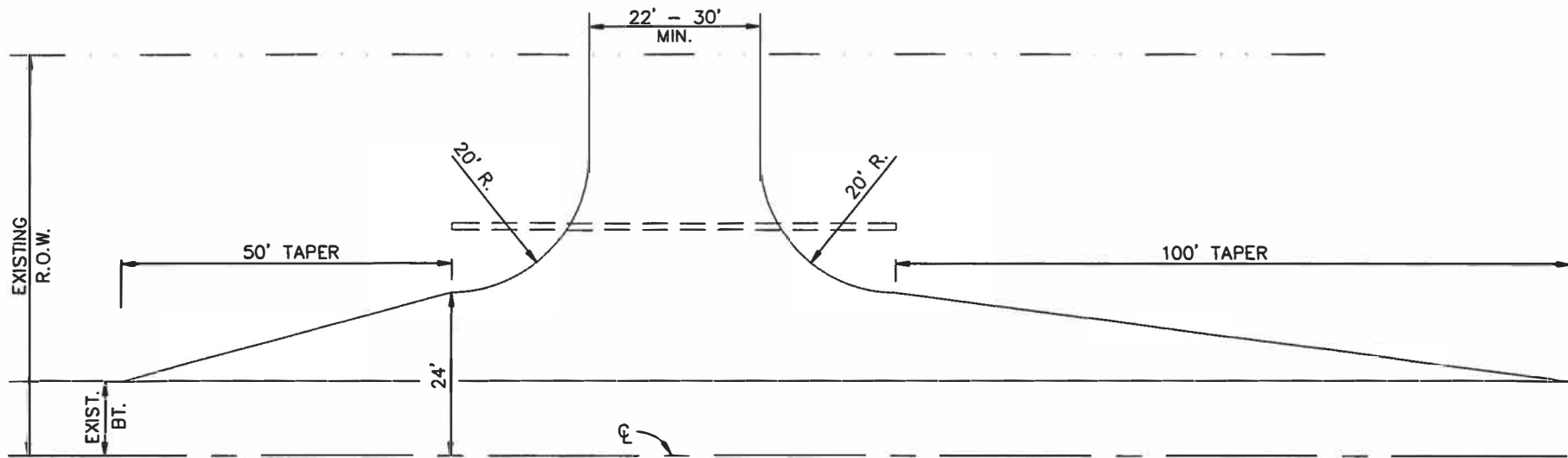

KENT COUNTY ROAD COMMISSION

STANDARD COMMERCIAL DRIVEWAY

DETAIL "C"

PRIVATE STREET ENTRANCE (EXAMPLE) RURAL COUNTY ROAD
WITH A.D.T. OVER 2,000 AND COMMERCIAL DRIVEWAY APPROACH

FOR CULVERTS WHERE APPLICABLE, CONCRETE PIPE
IS REQUIRED ON ALL CURBED DRIVES. (CLASS A
CONC. MIN. 12" I.D.)

CURB AND GUTTER IS REQUIRED

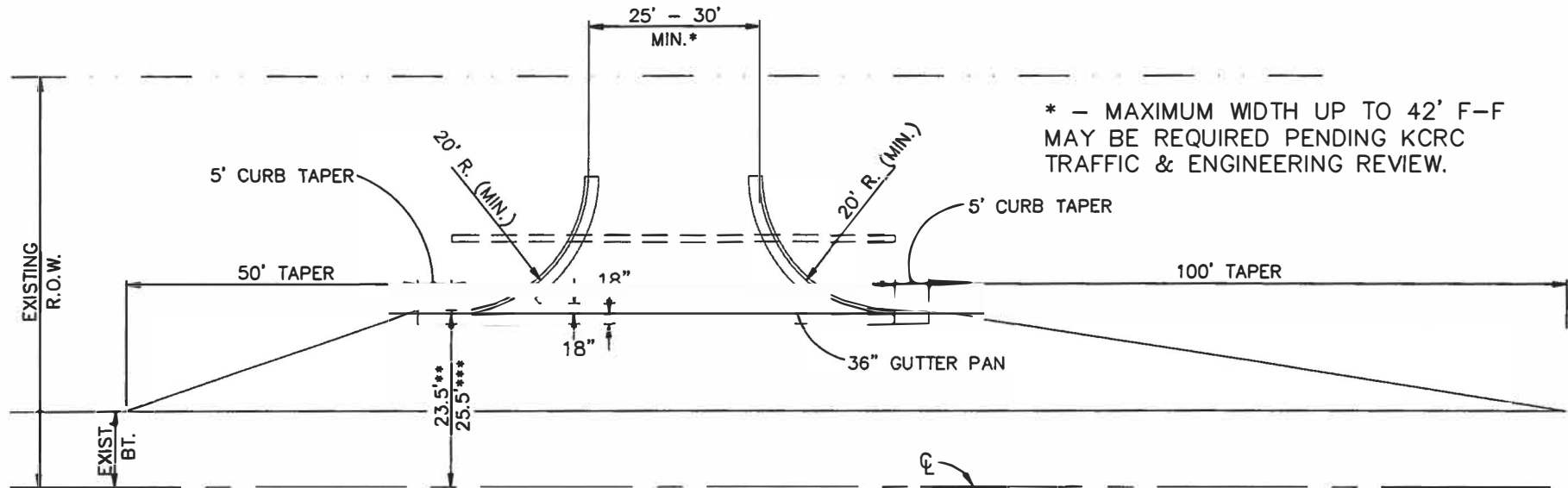

* - MAXIMUM WIDTH UP TO 42' F-F
MAY BE REQUIRED PENDING KCRC
TRAFFIC & ENGINEERING REVIEW.

** LOCAL ROAD STANDARD OFFSET
*** PRIMARY ROAD STANDARD OFFSET

K.C.R.C. GENERAL NOTES

1. All workmanship and materials shall be according to the current Michigan Department of Transportation (M.D.O.T.) Standard Specifications for Construction.
2. Driveway approach to be bituminous or concrete. Concrete shall be used when the distance between the new curb and the highway right of way, or street edge of sidewalk, is 15 feet or less.
3. Concrete curb and gutter to be F-4 or as approved by the K.C.R.C. Engineer.
4. Where poor soil conditions exist, the depth of the gravel and sand subbase between the new curb and existing pavement, shall be determined by the Engineer.
5. No advertising sign or device shall be placed in, or overhang into the existing highway right of way.
6. Kent County Road Commission is to be notified 48 hours prior to the start of construction; excluding Saturdays, Sundays, and Holidays. This agency will inspect all work within the highway right of way. Concrete forms must be inspected by the K.C.R.C. Inspector before concrete is poured.
7. Prior to the start of construction, it will be mandatory for the applicant or contractor to have in place the necessary safety traffic signs, cones, barricades and any other safety device to insure safety to the public. No lane closures will be allowed from November 1st to April 1st unless approved by the K.C.R.C. Engineer.
8. All disturbed areas are to be leveled and restored with topsoil, seeded with an approved turf seed mix, and allowed to grow to a mowable condition so as to prevent future erosion or maintenance problems. Slopes that are 1 on 2 or steeper shall be sodded.
9. The highway right of way shall not be used for private business purposes.
10. No parking of vehicles, equipment, or material storage permitted within the highway right of way.
11. The owner must provide for adequate drainage from parking areas, and clear same with the Kent County Road Commission. Issuance of a permit does not alleviate owner of this responsibility.
12. Culverts, storm sewers, or other drainage structures shall be inspected by the Kent County Road Commission Inspector before backfill is placed.
13. Water from this property shall not drain into County or State Highway right of way without approval.
14. Resurface existing public roadway as necessary to fit drive approach, correct crown, correct drainage, or repair damage by construction. Sawcut remove all curb, concrete, and bituminous as required by the Kent County Road Commission.
15. Property owner is responsible for obtaining a Soil Erosion & Sedimentation Control Permit for any earth change greater than one acre, or within 500 feet of a regulated water of the State.
16. A utility permit must be obtained for placement and hookup of utilities (i.e. water, gas, oil, sewer, telephone, electric, cable TV, etc.) in the highway right of way.
17. Contact "Miss Dig" toll free at 1-800-482-7171 or 811 three (3) days prior to the start of construction, excluding Saturdays, Sundays, and Holidays.
18. Additional work (bituminous paving, grading, etc.) may be required by the Kent County Road Commission Inspector to correct poor workmanship and/or alleviate drainage problems.
19. All work in the highway right of way approved by a commercial drive/private street approach permit must be completed within one year of permit issuance date.
20. Performance Bonds, Letters of Credit, and Bank Cashiers Checks (in lieu of a bond) must remain in effect through one winter season to spring season after the completion of work allowed under the permit.
21. Kent County Road Commission reserves the right to terminate or revoke any permit if any terms, construction, or safety requirements as deemed necessary by the Road Commission or as shown on the approved permit plan are not met, or resolved in a timely manner.
22. Any paving performed in the highway right of way between November 1st to May 1st requires prior approval from the K.C.R.C. Engineer.
23. All overcuts in sawcut pavement must be filled and sealed with a sealer approved by the Kent County Road Commission.
24. Any landscaping in the highway right of way must be noted on the permit/drive plan approved by the K.C.R.C.

(Revised June – 2018)